

## 2m Band Transverter for the IC7300 SDR Transceiver

First published in DUBUS magazine 3/2019

DB6NT 12.2019

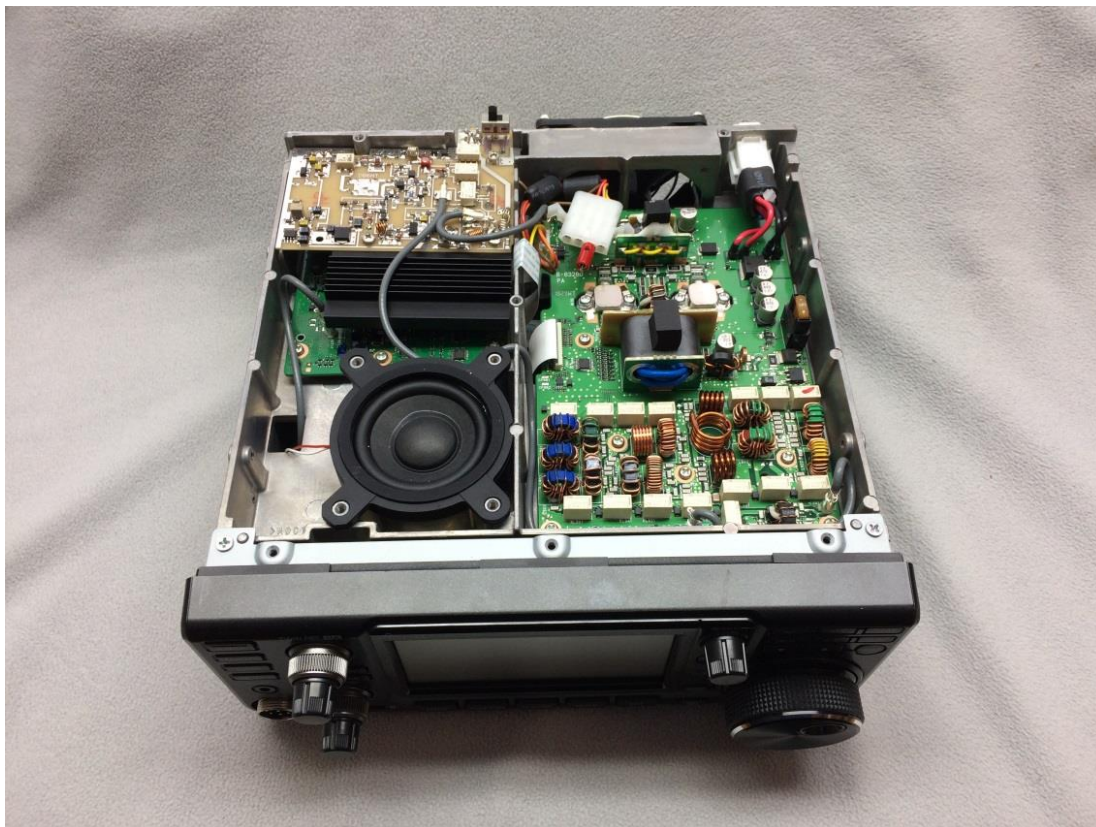

The Shortwave Transceiver IC7300 has many features that are also good for use on VHF/UHF/SHF and especially on the microwave bands.

These include the spectrum display and the waterfall diagram. The speech memory can call CQ and can be used to record DX-QSOs. Of course you can do it all with external computers, SDR sticks, sound cards and monitors, but this increases the size of the “equipment park” considerably.

Most ham friends anyway have always lack of space in the shack. As a fan of standalone devices, the IC7300 seems to me a good alternative. Unfortunately, it has no transverter-out or no 2m module. In order to be able to use the inexpensive and compact device nevertheless, I decided to develop a small printed circuit board with a 2m transverter, which enables the control for all further microwave transverters.

At this point it should be mentioned that the IC7300 is not a high-signal repeater for 2m contest operation!

Thus, the dimensioning of the transverter is adapted to the technical conditions of the IC7300. This solution is in no way comparable to the 2m contest combination K3 and TR 144 h +40 PRO.

### Which technical data should the Transverter achieve?

- a.) Small noise figure: approx. 1,3 dB
- b.) Sufficient gain : approx. 15 dB
- c.) Output power: approx. 2 Watts. For the DB6NT microwave transverters you need minimum 0.5 Watts without cable attenuation.
- d.) High frequency stability: +/- 0,5 ppm TCXO
- e.) Few side waves: approx. 60 dB through a three-circle helix filter
- f.) Little harmonics: approx. 60 dB through a 5-pole low pass filter
- g.) Large signal immunity: through use of a P-HEMT preamplifier with the ATF-54143 and a 17 dBm high level mixer ADE-1H.
- h.) Easy installation in the transceiver
- i.) Avoidance of „warranty loss“ by modification of the IC7300
- j.) Easy switching on/off from 2m to SW operation with a slide switch

### Description:

The circuit board described here is intended for installation in the transceiver. In this case, the connector strip on the rear wall, which is intended for the connection of an external tuner, is banned in the interior and the transverter circuit board is installed in its place.



The circuit separates the RF connection in the transceiver between the RF PCB and the PA PCB in transverter mode and thus enables the control of the transverter. The activation of the transverter module is done by pressing the slide switch on the top of the PCB.

Now the 2m signal is available at the SMA socket. The built-in KW-PA of the transceiver is terminated with 47 OHM in the input. A further deactivation of the PA is not intended, since otherwise interventions in the transceiver would be necessary, which exclude a possible warranty of the manufacturer.



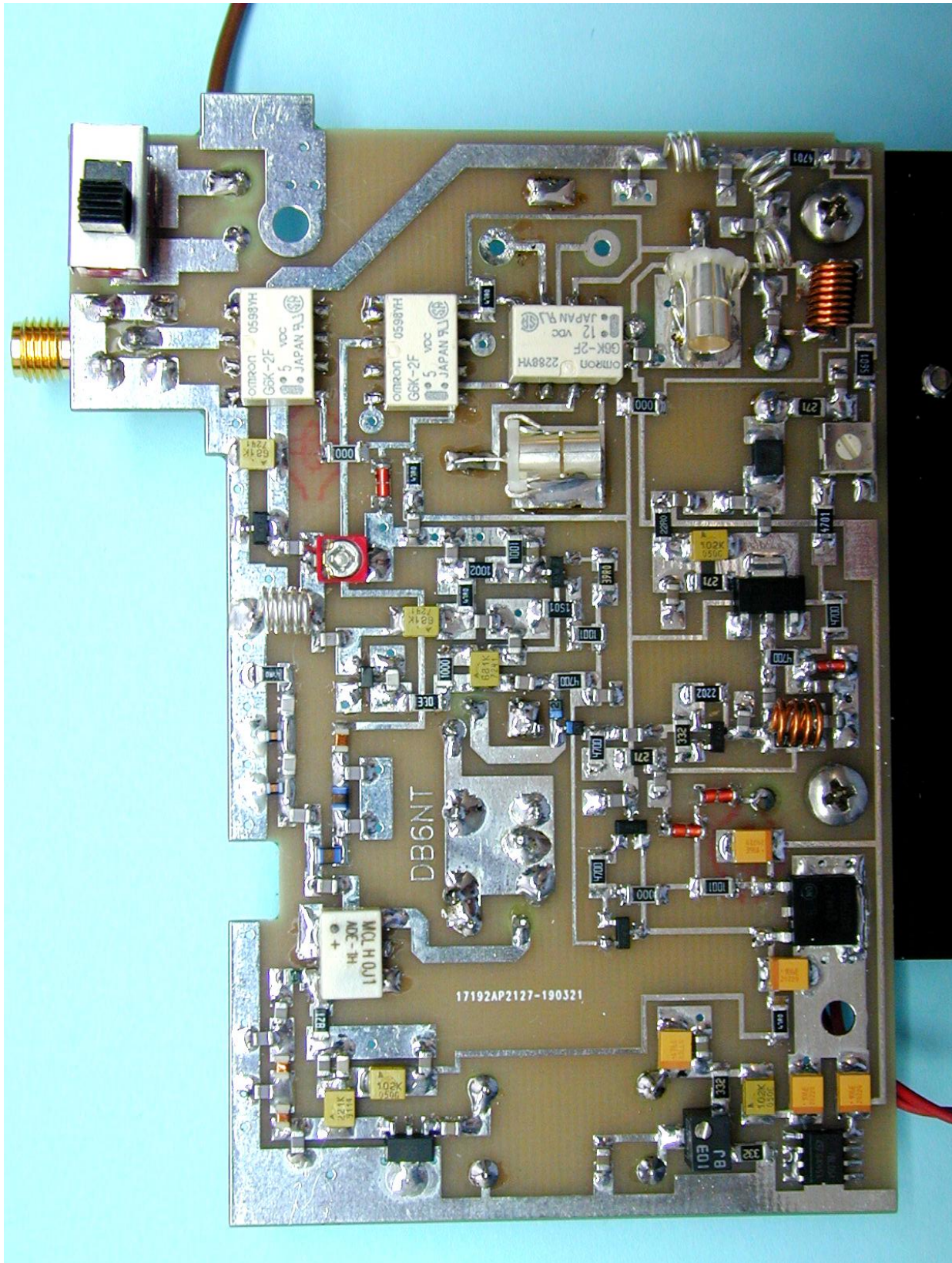

The printed circuit board is made of 1 mm thick epoxy material and is simply installed in the position shown in the photo. On the underside of the board are soldered two short pieces of 35 ohm 3.6 mm semi-rigid cables, which have the correct dimensions to fit into the sockets of the RF-UNIT of the transceiver. These short lengths of cable should be adjusted in length and orientation to the bush-



ings. The center conductors should be sharpened with the file. This facilitates the insertion into the sockets on the circuit board.

The assembly work should be done very carefully and without mechanical stress on the Transceiver circuit board.

The conductor plate is fixed by replacing the tapping screw on the edge of the RF-UNIT PCB with a longer (3 x 30mm) tapping screw with a spacer roller (18mm). It is also possible to use a M3 x 25 screw if no tapping screw is present. The screw can also be screwed in without prior thread cutting.

### **Construction order:**

- 1.) Equip PCB with all SMD components.
- 2.) Preparation and installation of all air coils. Depending on their diameter, they are wound on a correspondingly strong mandrel (drill shank).
- 3.) Solder Helixfilter, TCXO, socket and slide switch.

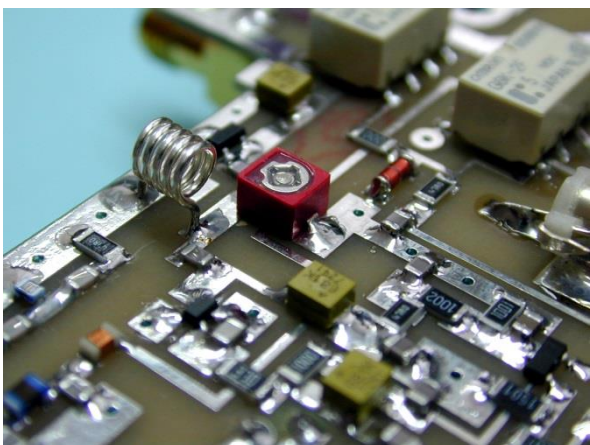
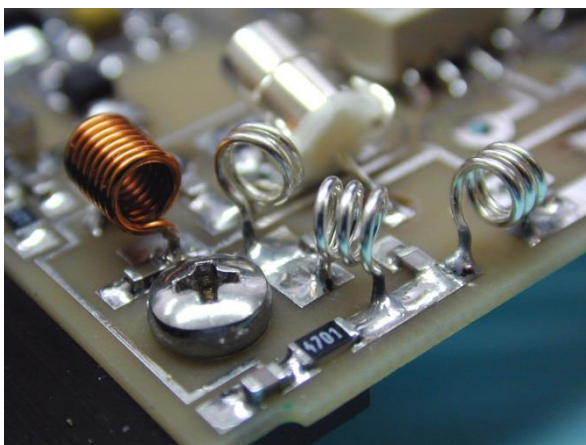
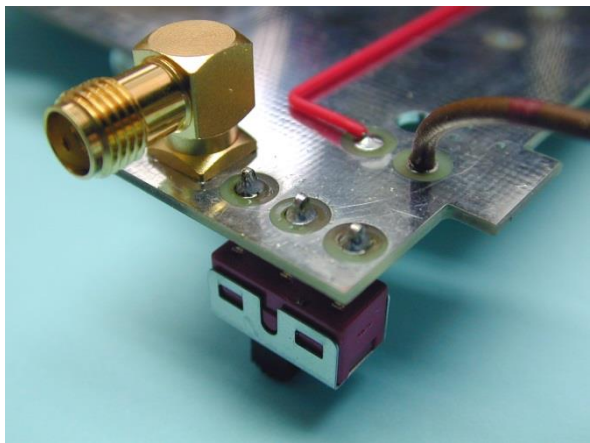
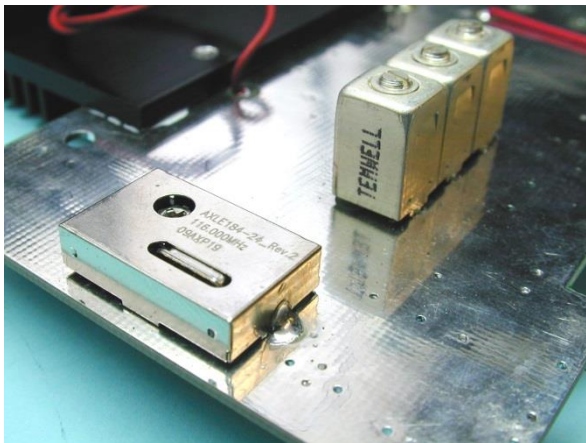

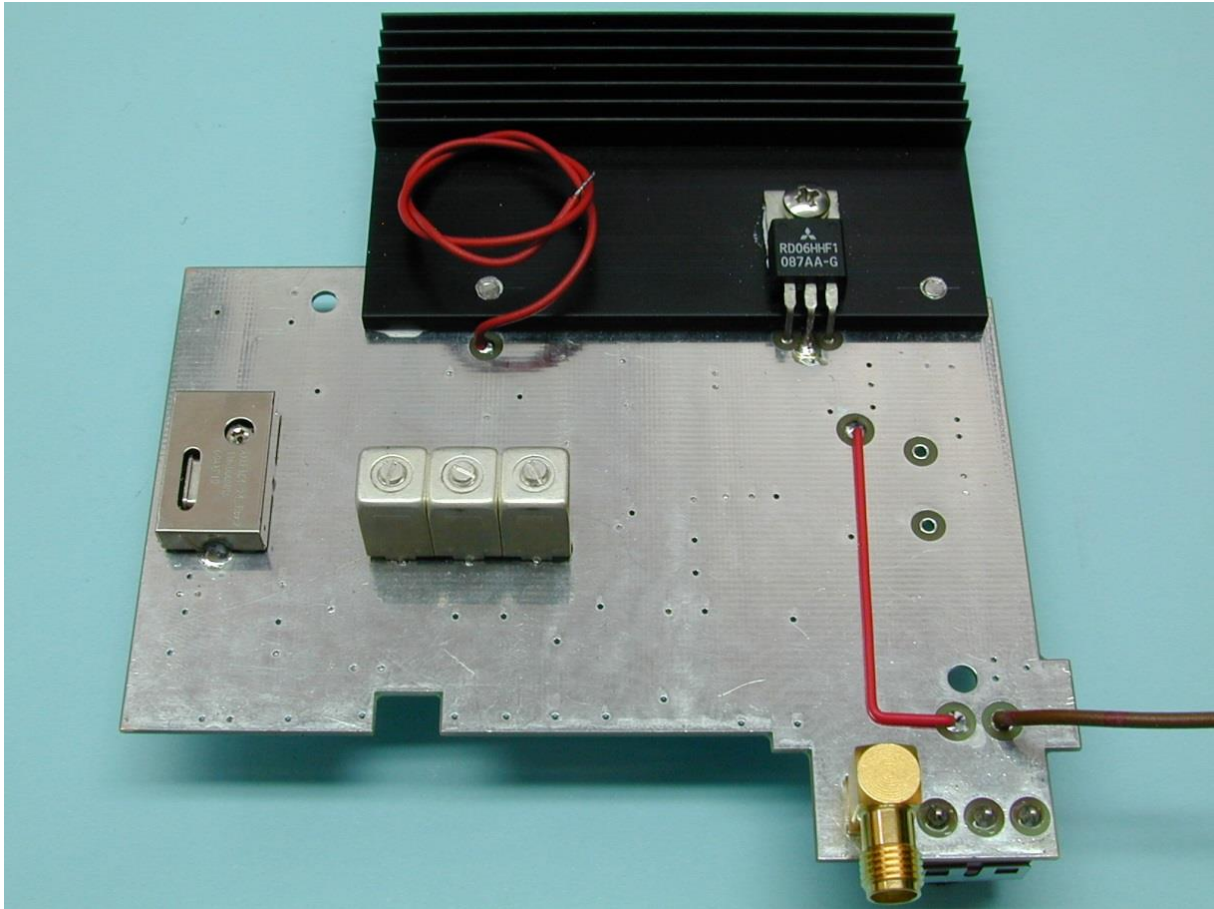

- 4.) Hold heat sink to mark the holes on the circuit board.
- 5.) Drill heat sink with three M3 threads for fixture and PA transistor
- 6.) Screw on the heat sink and install the PA transistor as it can be seen in the photos.
- 7.) Attaching the solder bridge and connection wires for +12V and PTT.
- 8.) Insulate and sharpen coax pieces (35 ohms) at the ends. The total length of the cable pieces is 21 mm. You have to strip 4 mm of each side. The length of the outer conductor is thus 13.0 mm.

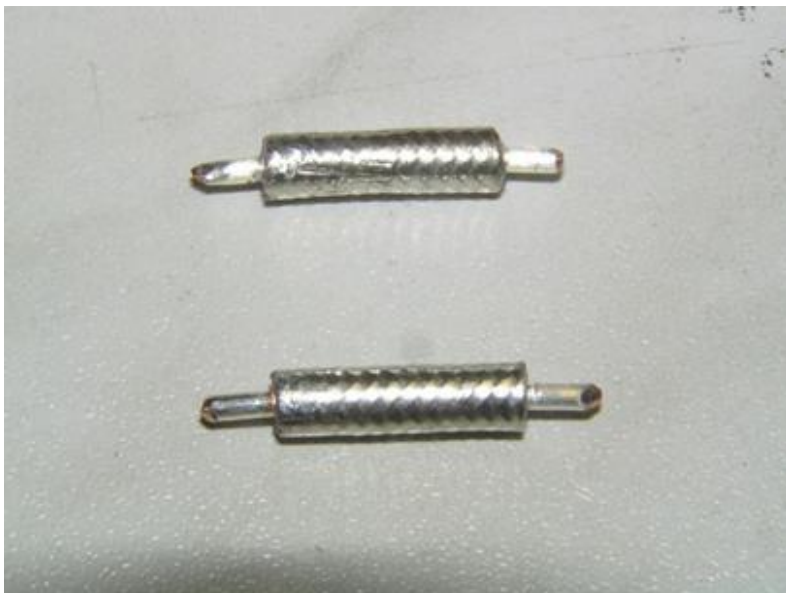



9.) Insert coax pieces into the sockets of the transceiver. Pull out the plug first.

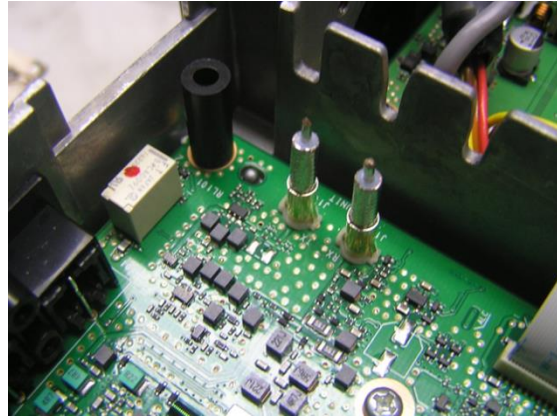
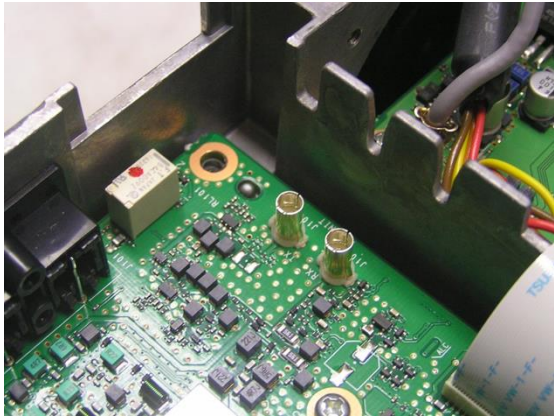

10.) Put on the PCB and thread the center conductors of the coax pieces into the holes.

11.) Solder the center conductor.

12.) Pull out the PCB together with the coax pieces.

13.) Solder the outer conductor of the coax pieces with the underside of the PCB (ground). Do NOT change the orientation of the coax pieces.

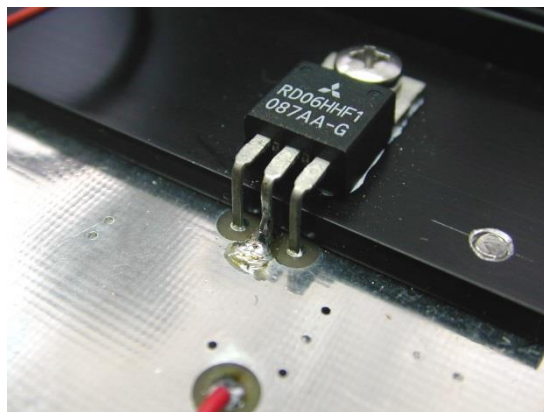
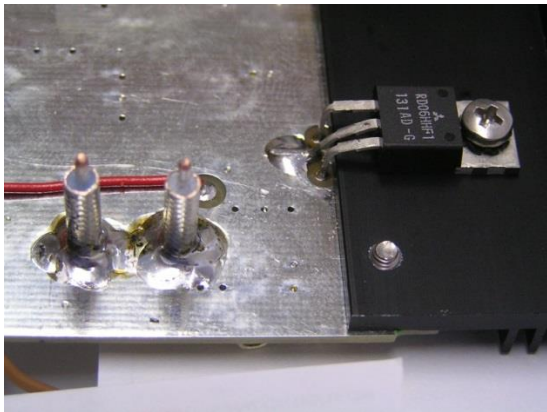

14.) Connect the PTT wire to the PTT socket of the IC7300

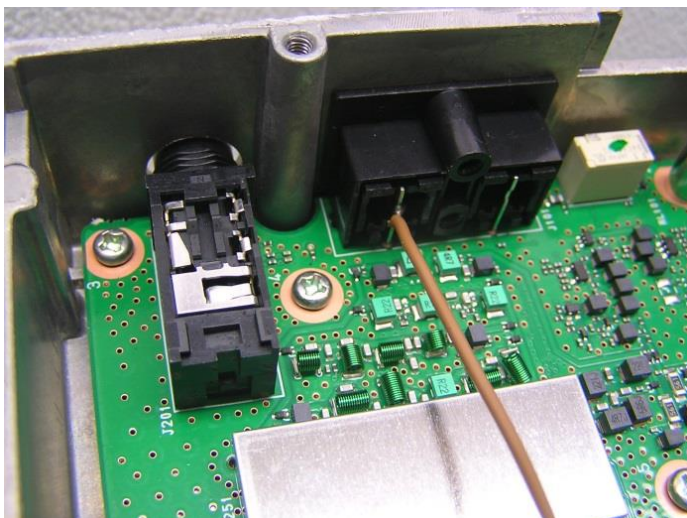

### Adjustment of the transmission piece

In general, the adjustment at the measuring station with the corresponding devices is preferable. However, I want to show with the following description that it works without large measurement technology.

- 15.) Connect the transverter IF-TX socket to the corresponding socket of the transverter via a previously prepared test coax cable (about 20 cm long) with a TMP-S plug and a TMP-V socket.
- 16.) Bring the 1K potentiometer for the standby current of the PA to the center position.
- 17.) Connect the power meter via a cable to the SMA socket of the transverter.
- 18.) Place 13.8V from a laboratory power supply (1.2A) to the miniplug for +12V.
- 19.) Switch on the transverter by the slide switch.
- 20.) Set the IC7300 to 28.5 MHz and set the transmit power to 10% in position FM.
- 21.) Switch to transmission and adjust the transmission power to maximum by means of the 3 tuning screws of the helix filter. Then do the adjustment of the coil L1 by pulling up and compressing to the maximum transmission power.
- 22.) Now the power regulator of the IC7300 is set to 50% and the coil L5 is also to be optimized. The coils L3 and L4 are still to be readjusted.
- 23.) The standby current of the PA transistor without HF control should be approx. 80 mA.
- 24.) At 100% drive power of the IC7300, it is possible to achieve up to 4 watts RF saturation power when the transverter is cold.
- 25.) Disconnect the test coaxial cable, unscrew the mounting strip of the transceiver circuit board and put on the spacer roller.
- 26.) Carefully place the transverter PCB back on and screw it on.
- 27.) Insert the connection wire with the miniplug for 12 V to the tuner connector coupler. Contact number 3 orange
- 28.) The circuit board is now on the edge of the chassis and a connector. The board is not 100% straight, but very well and stable fitted.



29.) Lay the flat-ribbon connector over the middle wall of the transceiver so that it does not disturb or damage it.

30.) **Adjustment of the receiving piece**

31.) Place the transceiver in the USB position at 28.5 MHz with the preamplifier P.AMP2 switched on.

32.) Connect a suitable antenna to the SMA socket of the transverter and adjust the noise of the receiver with the trimmer CRX to maximum.

33.) Now you can also determine by switching the transverter on/off a significant noise difference. Even the noise is louder with antenna than without.

34.) **Frequency adjustment, calibration**

35.) The TCXO used here is also installed in the TR144 PRO. It is very frequency stable and also has a very low phase noise.

Receive a frequency accurate beacon or a signal from a transmitter. Adjustment of the frequency by the F-ADJ. 10K pot at the TCXO. Better, of course, is the comparison with a frequency counter, which is coupled to the mixer input 4.7 ohms. If the control range is insufficient, the trimmer should be readjusted in the TCXO.

36.) Try it, do a test QSO, and then screw the transceiver back together.

37.) Finished!

**Achieved technical data:**

noise figure:	typ. 1,3 dB
gain:	typ. 15 dB
output power:	typ. 2 Watt
secondary wave suppression:	typ. 60 dB
suppression of harmonics:	typ. 60 dB
LO phase noise :	typ. 155 dBc/Hz@10kHz

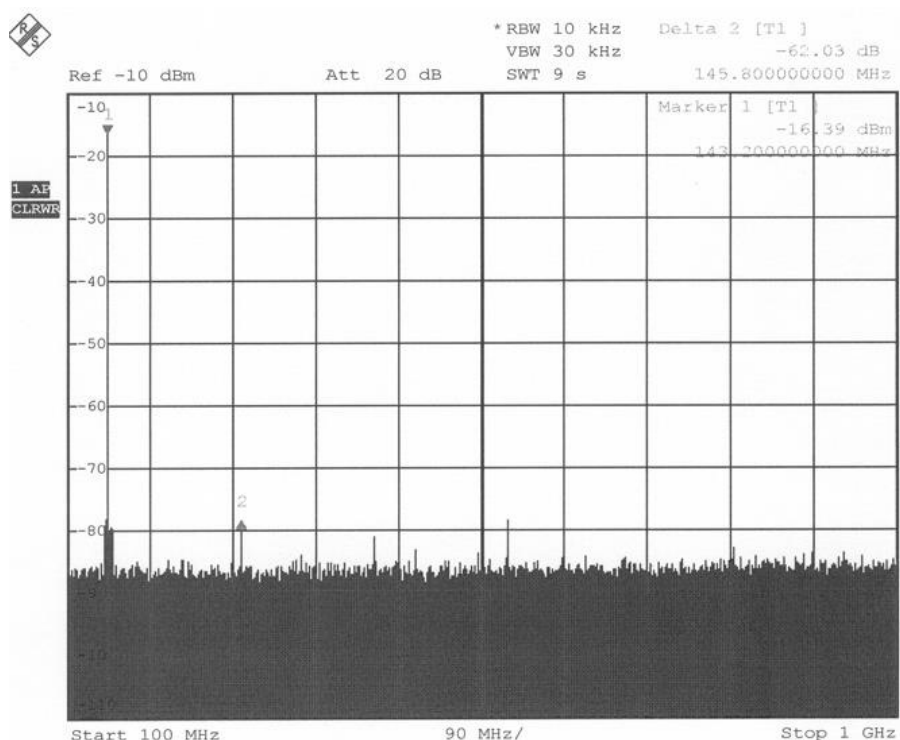



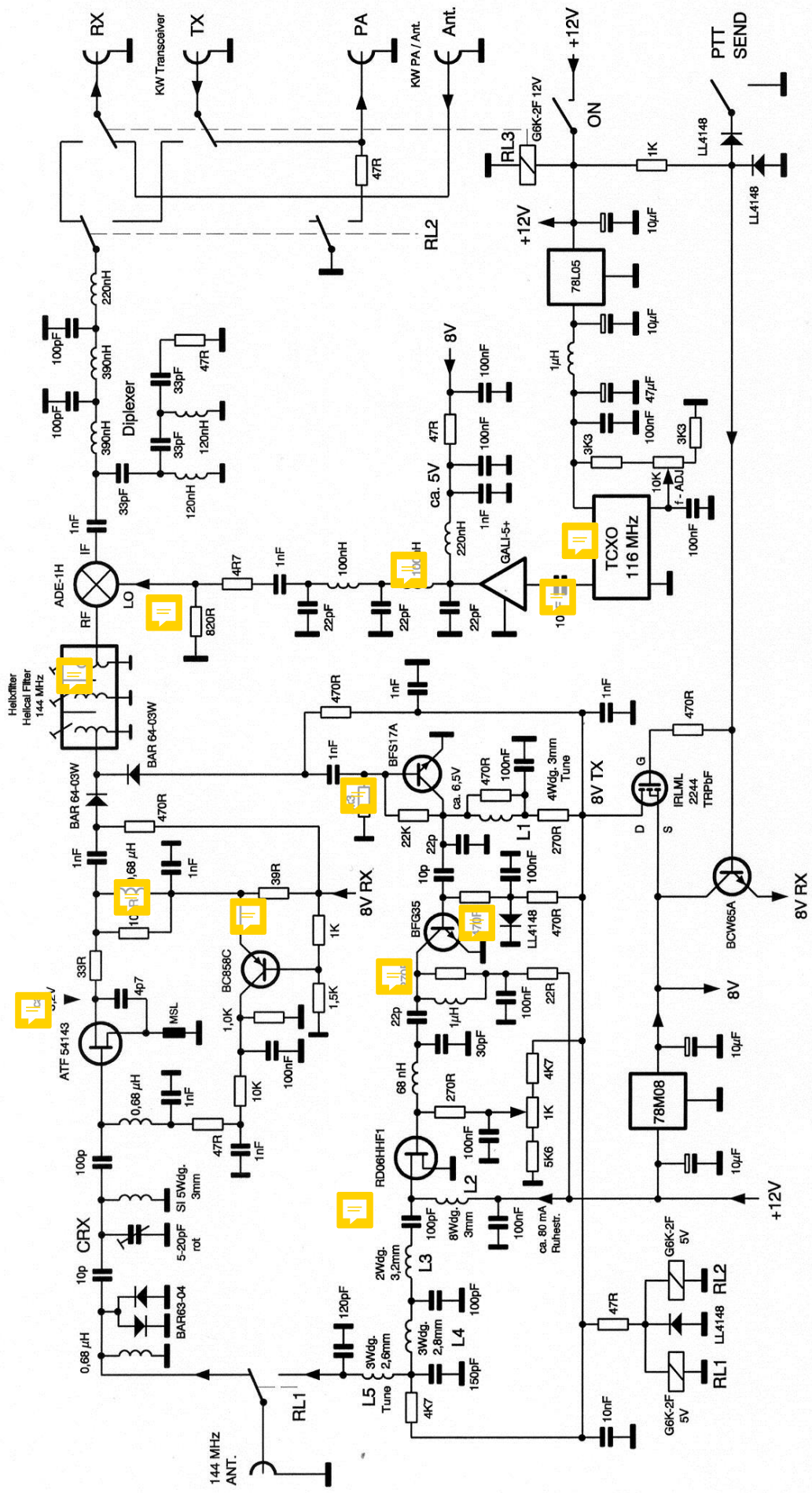



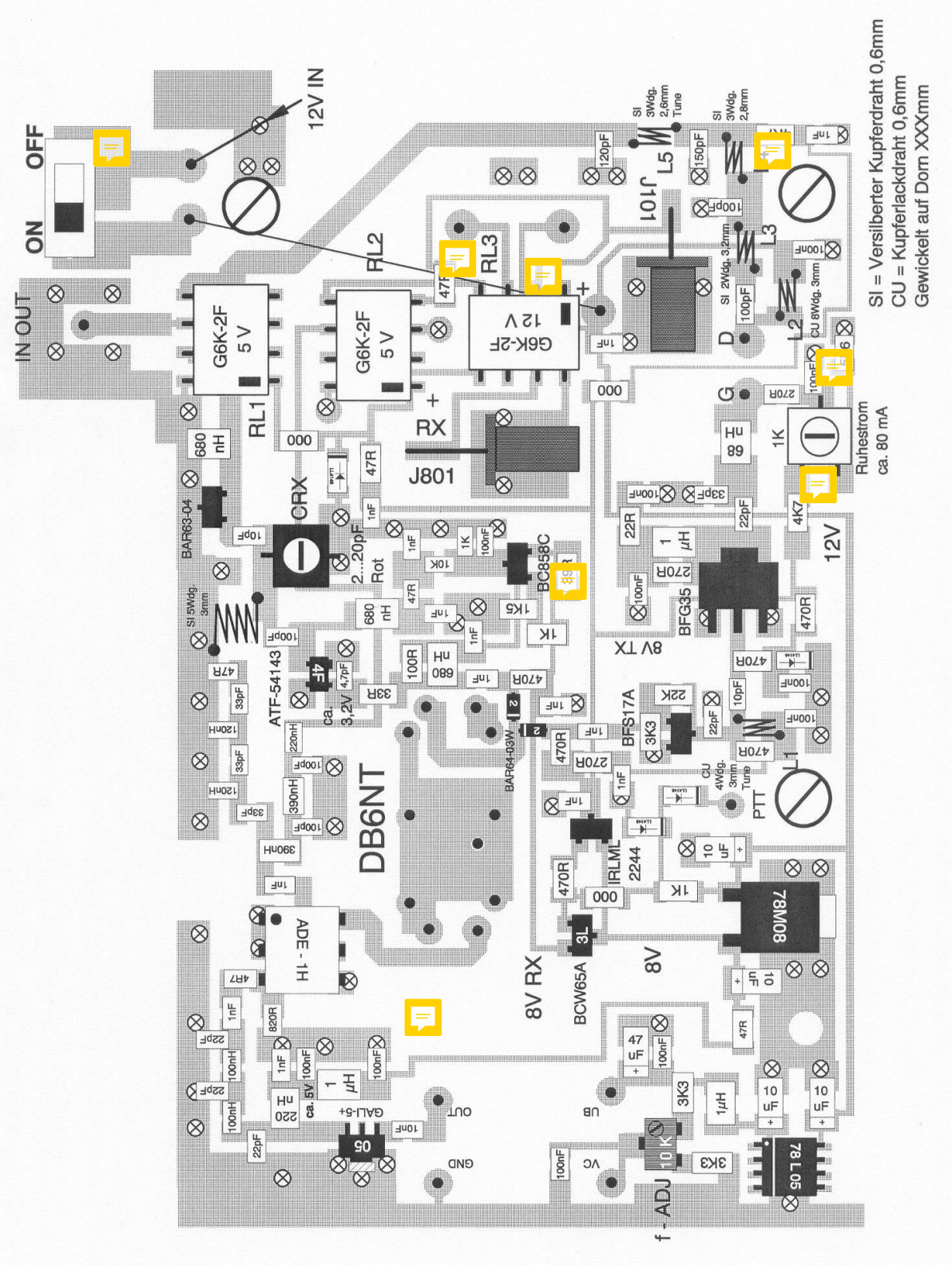

SI = Versilberter Kupferdraht 0,6mm  
 CU = Kupferlackdraht 0,6mm  
 Gewickelt auf Dorn XXXmm

Ruhestrom  
 ca. 80 mA

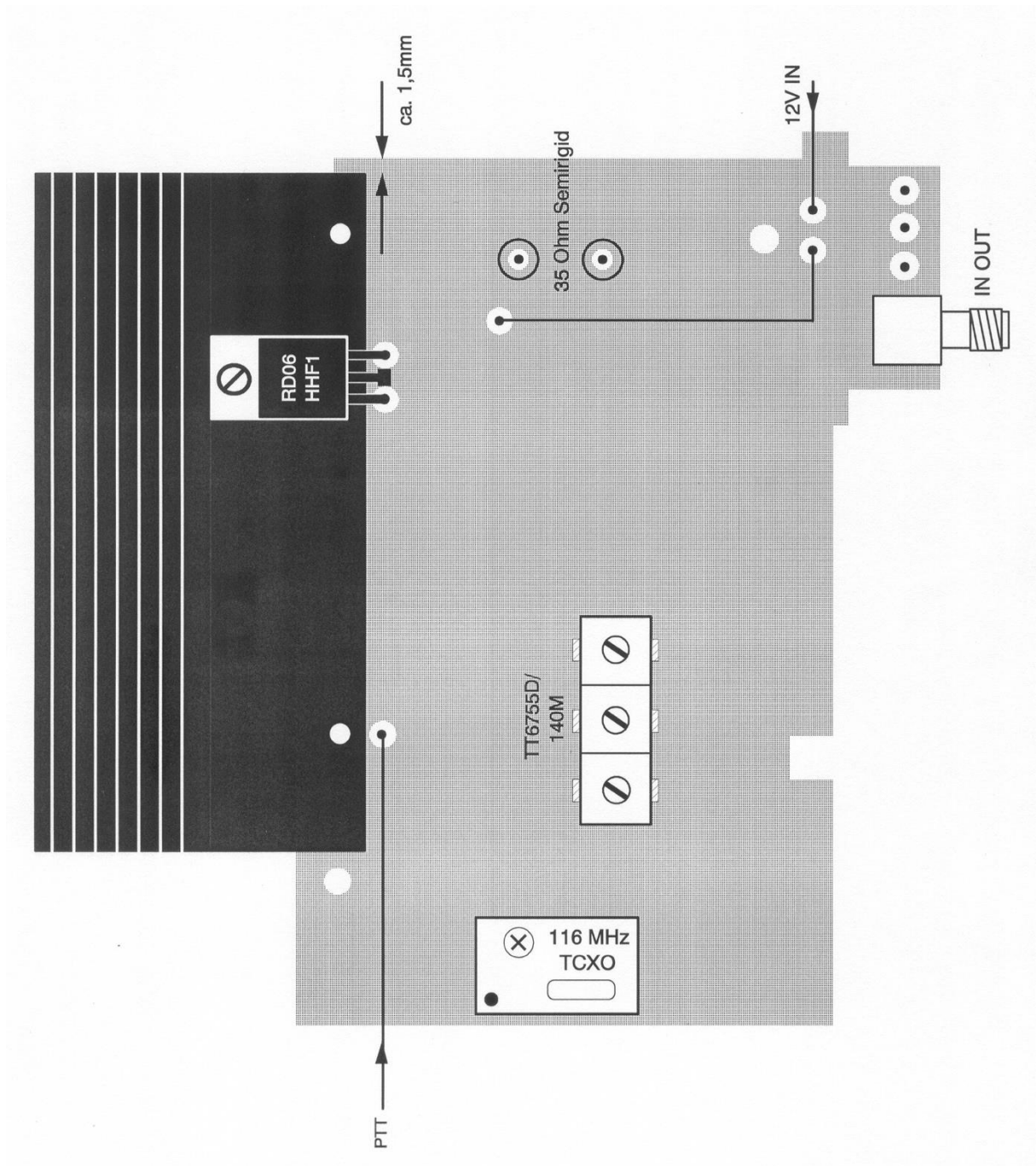

**Note of thanks:**

I would like to thank Sven DH8NAS for setting up the prototypes. These printed circuit boards were used to confirm the reproducibility of the circuit. Furthermore, many thanks to my son Matthias DK5NJ who did the proofreading and the translation to English.



### Pieces list and sources of supply:

1 piece	PCB	144TR7300	DB6NT	KUHNE electronic
1 piece	switch	SL19-121	Canal Electronic	
1 piece	Spacing roller	MR6-3.2X18	Quick-OHM	
1 piece	Allen screw	M3x25mm	Various	
3 pieces	screw	M3x5	Various	
1 piece	SMA angle print socket		Various	Funkamateur
1 piece	heatsink	SK 596 75 SA	Fischer elektronik	Bürklin
1 piece	Helixfilter	TT6755D/140M	Temwell	KUHNE electronic
1 piece	TCXO 116 MHz	AXLE184-24_Rev.2		KUHNE electronic
2 pieces	relay	G6K-2F 5V		Reichelt
1 piece	relay	G6K-2F 12V		Reichelt
2 pieces	socket	TMP-V		Funkamateur
2 pieces	Semi-Rigid cable	35 Ohm 3,6 mm	Various	KUHNE electronic
1 piece	Mixer	ADE-1H	Mini-Circuits	Various
1 piece	Transistor	RD06HHF1	Mitsubishi	Funkamateur
1 piece	Transistor	BFG35	Farnell	Conrad
1 piece	Transistor	BFS17A	Various	Farnell
1 piece	Transistor	IRLML2244	Various	Reichelt
1 piece	Transistor	BCW65A	Various	KUHNE electronic
1 piece	Transistor	BC858C	Various	Reichelt
1 piece	Transistor	ATF-54143 (SAV-541+)	AVAGO	KUHNE electronic
1 piece	MMIC	GALI-5+	Mini-Circuits	Funkamateur
1 piece	Diode	BAR64-04	Various	Bürklin
2 pieces	Diode	BAR64-03W	Dix.	Conrad
4 pieces	Diode	LL4148	Various	Reichelt
1 piece	IC	78L05	MC 78L05 ABDG	Reichelt
1 piece	IC	78M08 TO-252/DPAK	Various	Various
1 piece	Trimmer C	4,5...20pF Rot	Various	Conrad
1 piece	Trimmer R	10K Helipot	BOU 3269W-1-103	Reichelt
1 piece	Trimmer R	1K	23A-1,0K	Reichelt
3 pieces	inductor	680 nH / 1210	Various	Various
1 piece	Inductor	68 nH / 1210	Various	Various
3 pieces	Inductor	1 µH / 1210	Various	Various
1 piece	Inductor	220 nH / 1210	Various	Various
2 pieces	Inductor	100 nH / 0805	Various	Various
2 pieces	Inductor	120 nH / 0805	Various	Various
1 piece	Inductor	220 nH / 0805	Various	Various
2 pieces	Inductor	390 nH / 0805	Various	Various
3 pieces	Resistor	0 Ohm / 1206	Various	Various
1 piece	Resistor	4,7 Ohm / 0805	Various	Various
1 piece	Resistor	22 Ohm / 1206	Various	Various
1 piece	Resistor	33 Ohm / 1206	Various	Various
1 piece	Resistor	39 Ohm / 1206	Various	Various
5 pieces	Resistor	47 Ohm / 1206	Various	Various

1 piece	Resistor	100 Ohm / 1206	Various	Various
2 pieces	Resistor	270 Ohm / 1206	Various	Various
5 pieces	Resistor	470 Ohm / 1206	Various	Various
1 piece	Resistor	820 Ohm / 1206	Various	Various
3 pieces	Resistor	1 K Ohm / 1206	Various	Various
1 piece	Resistor	1,5 K Ohm / 1206	Various	Various
3 pieces	Resistor	3,3 K Ohm / 1206	Various	Various
2 pieces	Resistor	4,7 K Ohm / 1206	Various	Various
1 piece	Resistor	5,6 K Ohm / 1206	Various	Various
1 piece	Resistor	10 K Ohm / 1206	Various	Various
1 piece	Resistor	33 K Ohm / 1206	Various	Various
1 piece	capacitor	4,7 pF / 0805 / NPO	Various	Various
2 pieces	Capacitor	10 pF / 0805 / NPO	Various	Various
5 pieces	Capacitor	22 pF / 0805 / NPO	Various	Various
4 pieces	Capacitor	33 pF / 0805 / NPO	Various	Various
6 pieces	Capacitor	100 pF / 0805 / NPO	Various	Various
1 piece	Capacitor	120 pF / 0805 / NPO	Various	Various
1 piece	Capacitor	150 pF / 0805 / NPO	Various	Various
13 pieces	Capacitor	1 nF / 0805 / NPO	Various	Various
1 piece	Capacitor	10 nF / 0805	Various	Various
11 piece	Capacitor	100 nF / 1206	Various	Various
1 piece	Capacitor	47 µF / 1210 / 10V	Various	Various
4 pieces	Capacitor	10 µF / 1210 / 20V	Various	Various

#### **Important NOTE:**

For the operation of transmitting and receiving systems, the statutory regulations must be observed. Experience with SMD components and their processing is absolutely essential for the construction of the Transverter. It should not be the "SMD debut" in any case, since components with a very small design can be processed. Furthermore, basic knowledge in the construction of VHF circuits should be available.

Different components like FETs are very sensitive statically. ESD (Electrostatic Sensitive Device) protective measures during installation must be strictly adhered to.

**The assembly, as well as the installation of the PCB should be done with a practiced and careful hand! Please note: The installation is at your own risk.**

#### **FAQ:**

**Can I modify the transverter with more power to control my 2m PA?**

*In principle, yes, but you do not get the power loss / heat from the transceiver!*

**Is the frequency range 146 - 148 MHz also possible?**

*Yes, this requires the frequency expansion of the IC7300. The TX then goes up to over 32 MHz. The helical filter of the transverter and the coils must also be adjusted accordingly.*

*73 de DB6NT*